

VOLVO PENTA AQUAMATIC DUOPROP

D4-300/DP

221 kW (300 hp) crankshaft power acc. to ISO 8665



Available
with Joystick!

Exceptional diesel performance for its size

Volvo Penta's 4-cylinder D4-300 is developed from the latest design in modern diesel technology. The engine has common rail fuel injection system, double overhead camshafts, 4 valves per cylinder, turbocharger, compressor, and after-cooler. The interaction of these, the large swept volume, and the EVC system results in exceptional diesel performance combined with low emissions. The engine is extremely compact for its high output.



D4-300 with DP Duoprop drive

World-class performance

The common rail fuel injection system, controlled by EVC, and the compressor, in combination with a large swept volume, ensure unique torque over the whole speed range. The acceleration is very powerful, with virtually no sign of smoke. This matched with the engine's high load carrying capability creates a sporty feeling and power, when needed.

Compact and robust

The engine is extremely compact for its large swept volume and high output. With the rear-end transmission, driving the high-pressure injection pump and the camshafts, a high degree of integrated systems, a high-efficiency aftercooler, a marinization performed with very few hoses, and a fully symmetric engine, the package simply gets that compact.

The rigid cast-iron cylinder block and head, combined ladder frame and balance shafts, and exactly controlled (up to three steps) fuel injection gives excellent onboard comfort with low noise and vibration levels.

EVC-E

The next generation of the proven Electronic Vessel Control offers further enhancements to the driver experience.

E-key is standard, optional integrated autopilot and Joystick driving are possible.

Ergonomically designed controls engage smoothly and allow for maneuvering with fingertip precision. Pushbuttons integrated on the control give easy access to optional functions such as Power Trim Assistant, Tow Mode and Single Lever Control.

Complete the helm with your choice of easy to read gauges and displays, including the 7" color display. Add the trip computer function for accurate fuel management and minimized environmental impact. Engine synchronization is standard in twin installations.

The Duoprop drive

The corrosion-resistant aluminum drive is based on the experience with the well-proven original DP drive, and fully matched to the very powerful engine. The modern styling, the hydrodynamic design for low drag, and the Duoprop high strength bronze propellers, specially developed for the drive, make the package complete. This results in unbeatable boat characteristics in terms of acceleration, top speed, and drivability.

The drive comes equipped with fully hydraulic further developed X-act steering. It features integrated external steering cylinders, controlled by an exact feedback valve as standard.

The integrated exhaust system and seawater intake, a hallmark for Volvo Penta, are also standard.

Meeting new emission standards

The common rail injection system in combination with electronics and an advanced combustion system are setting new standards in minimizing noxious emissions and particulates. The engine complies with IMO NOx limits and the comprehensive emission requirements EU RCD and US EPA Tier 3.

The DP drive has been designed to lead exhaust gases into the propeller path, to avoid the "station wagon effect" and keep noise levels at a minimum.

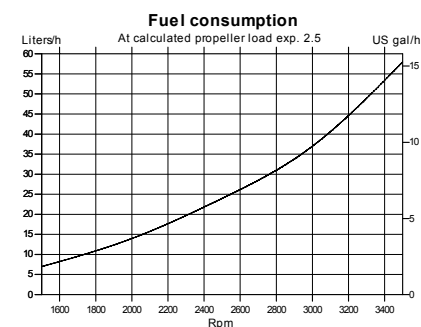
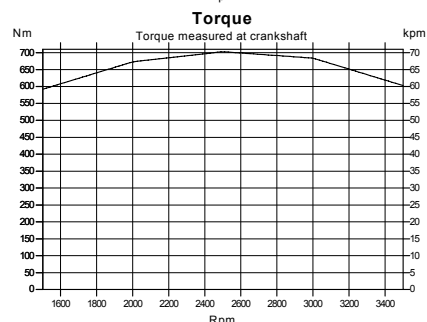
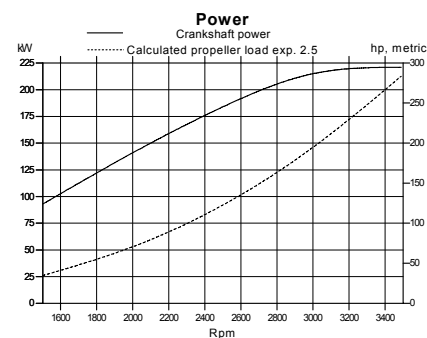

**VOLVO
PENTA**

D4-300/DP

Technical description:

Engine block and head

- Cylinder block and cylinder head made of cast-iron
- Combined ladder frame and balance shafts
- 4-valve technology with hydraulic lash adjusters
- Double overhead camshafts
- Oil-cooled pistons with two compression rings and one oil scraper ring
- Integrated cylinder liners
- Replaceable valve seats
- Five-bearing crankshaft
- Rear-end transmission

Engine mounting

- Flexible engine mounting

Lubrication system

- Easily replaceable separate full-flow and bypass oil filter
- Seawater-cooled tubular oil cooler

Fuel system

- Common rail fuel injection system
- Control unit for processing the injection
- Fine filter with water separator

Air inlet and exhaust system

- Belt-driven compressor with silencer of absorption type on both inlet and output port

- Air filter with replaceable insert
- Crankcase gases vented into the air inlet
- Exhaust elbow or exhaust riser
- Freshwater-cooled turbocharger
- Loss of sea water alarm

Cooling system

- Thermostatically regulated freshwater cooling
- Tubular heat exchanger with separate large volume expansion tank
- Coolant system prepared for hot water outlet
- Seawater strainer and easily accessible impeller pump

Electrical system

- 12V two-pole electrical system
- 115A marine alternator with Zener-diodes to protect the system from peak voltage, and integrated charging regulator with battery sensor cable for maximum use of alternator
- Fuses with automatic reset
- Auxiliary stop button

Instruments/control

- Complete instrumentation including key switch and interlocked alarm
- Digital Power Trim instrument with analog or digital reading
- EVC monitoring panels for single or twin installations

- Electronic shift and throttle
- Plug-in connectors

Drive

- Complete with transom shield, and installation components
- Max tilt angle 50° (adjustable)
- Protective zinc anodes to prevent corrosion
- Built-in kick-up function to reduce possible damage, in the event the drive strikes an underwater object
- Electrical shifting performed by electronic actuator
- Power Trim with one-button operation in twin installation
- Fully integrated water inlet and exhaust system
- Isolated propellers to prevent corrosion
- Fully hydraulic power-assisted steering system
- Optional electronic steering – prerequisite for Sterndrive Joystick. Twin installation only. This option is not retrofittable.

Accessories

An extensive range of accessories are available. For detailed information, please see the Accessories & Maintenance Parts catalog (www.volvopenta.com).



The Joystick Revolution (option)

Crowded marina. Strong side wind. Tight berth. Situations that can make even the most seasoned skipper a little edgy. Not anymore. Volvo Penta Sterndrive Joystick puts you in total control and lets you maneuver in any direction – sideways, diagonally, forward, backward or rotate – with just one hand.

Visit volvopenta.com to see for yourself!

Contact your local Volvo Penta dealer for further information. Not all models, standard equipment and accessories are available in all countries. All specifications are subject to change without notice.

The engine illustrated may not be entirely identical to production standard engines.

Technical Data

Engine designation	D4-300 A
Crankshaft power, kW (hp)	221 (300)
Propeller shaft power, kW (hp)	214 (291)
Engine speed, rpm	3500
Displacement, l (in ³)	3.7 (224)
Number of cylinders	4
Bore/stroke, mm (in.)	103/110 (4.06/4.33)
Compression ratio	17.5:1
Volvo Penta Duoprop drive	DPH
Ratio	1.76:1
Dry weight with DP, incl. prop. & PS, kg (lb)	663 (1462)

Duty rating: R5

Technical data according to ISO 8665. With fuel having an LHV of 42,700 kJ/kg and density of 840 g/liter at 15°C (60°F). Merchant fuel may differ from this specification which will influence fuel consumption.

The engine complies with IMO NOx and the comprehensive emission requirements US EPA Tier 3 and EU RCD.

Dimensions D4-300/DP

Not for installation

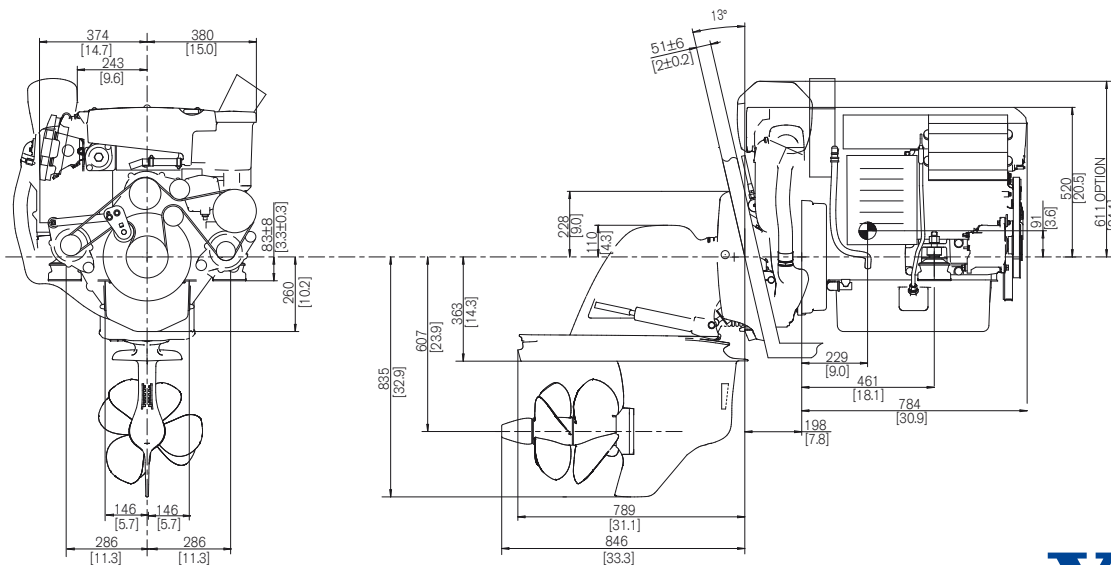

VOLVO PENTA

AB Volvo Penta
SE-405 08 Göteborg, Sweden
www.volvopenta.com